

Chip Type 85°C Capacitors (height:5.5mm,8.0mm)

GREEN CAP

SMD

Anti-cleaning solvent

- Compatible with surface mounting for 5.5mm, 8.0mm high capacitors.
- Supplied with carrier taping.
- Guarantees 2000 hours at 85°C.

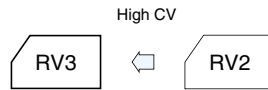

Marking color : Black print

Specifications

Item	Performance							
Category temperature range (°C)	-40 to +85							
Tolerance at rated capacitance (%)	±20 (20°C,120Hz)							
Leakage current (µA)	Less than 0.01CV or 3 whichever is larger(after 2 minutes) C: Rated capacitance(µF); V: Rated voltage(V) (20°C)							
Tangent of loss angle (tanδ)	Rated voltage (V)	6.3	10	16	25	35	50	
	tanδ (max.)	0.42	0.32	0.26	0.18	0.14	0.12	
Characteristics at high and low temperature	Impedance ratio (max.)	Z-25°C / Z+20°C	4	3	2	2	2	2
		Z-40°C / Z+20°C	8	8	5	5	4	4
Endurance (85°C) (Applied ripple current)	Test time	2000 hours						
	Leakage current	The initial specified value or less						
	Percentage of capacitance change	Within ±30% of initial value						
	Tangent of the loss angle	300% or less of the initial specified value						
Shelf life (85°C)	Test time : 1000 hours; other items are the same as those for the endurance. Voltage application treatment : According to JIS C5101-1							
Applicable standards	JIS C5101-1, -18 1998 (IEC 60384-1 1992, -18 1993)							

Outline Drawing

Unit: mm

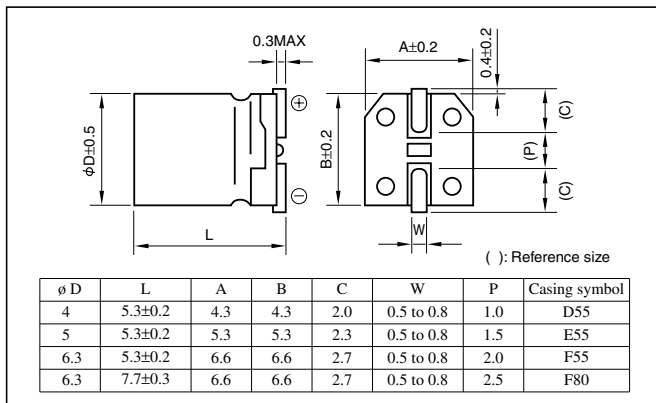

- Land pattern size is described on page 10.
- The taping specifications are described on page 11.
- Soldering conditions are described on page 28.

Coefficient of Frequency for Rated Ripple Current

Rated voltage(V) \ Frequency(Hz)	50	120	1k	10k · 100k
6.3 to 16	0.80	1	1.15	1.25
25 to 35	0.80	1	1.25	1.40
50	0.70	1	1.35	1.50

Part numbering system (example: 16V220µF)

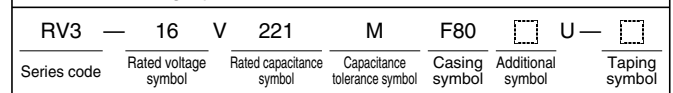

Standard Ratings

Rated capacitance(µF)	Item	6.3			10			16			25			35			50		
		Case	ESR	Rated ripple current	Case	ESR	Rated ripple current	Case	ESR	Rated ripple current	Case	ESR	Rated ripple current	Case	ESR	Rated ripple current	Case	ESR	Rated ripple current
4.7		—	—	—	—	—	—	—	—	—	—	—	—	—	—	—	—	—	—
10		—	—	—	—	—	—	—	—	—	—	—	—	—	—	—	—	—	—
22		—	—	—	4x5.3	24	26	4x5.3	20	30	4x5.3	30	23	4x5.3	23	27	5x5.3	20	34
33		4x5.3	21	28	4x5.3	16	33	5x5.3	13	44	5x5.3	9.0	54	6.3x5.3	7.0	67	6.3x7.7	6.0	82
47		4x5.3	15	34	5x5.3	11	45	5x5.3	9.2	50	6.3x5.3	6.4	75	6.3x7.7	4.9	90	6.3x7.7	4.2	98
68		5x5.3	10	47	5x5.3	7.8	54	6.3x5.3	6.3	74	6.3x5.3	4.4	90	6.3x7.7	3.4	109	—	—	—
100		5x5.3	7.0	58	—	—	—	6.3x5.3	4.3	103	6.3x7.7	3.0	124	—	—	—	—	—	—
150		6.3x5.3	4.6	83	6.3x7.7	3.5	98	6.3x7.7	2.9	109	—	—	—	—	—	—	—	—	—
220		6.3x7.7	3.2	113	6.3x7.7	2.4	130	6.3x7.7	2.0	144	—	—	—	—	—	—	—	—	—
330		6.3x7.7	2.1	139	—	—	—	—	—	—	—	—	—	—	—	—	—	—	—

(Note) Rated ripple current : 85°C, 120Hz; ESR : 20°C, 120Hz

NOTE

Design, Specifications are subject to change without notice. Ask factory for technical specifications before purchase and/or use.